



AHS Series

Features:

- Vortex impeller with abrasive-resistance resin (TPU), suitable for construction site.
- Double mechanical seal with silicone carbide, equipped in the oil chamber.
- High efficiency motor with auto reset thermal protector prevent the abnormal accident.
- Designed agitator to keep free from air lock and sand block.
- Auto version for small pit usage.

Performance curve

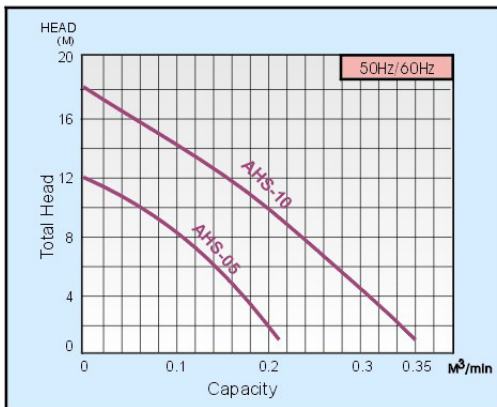

Agitator



Abrasive resistant impeller



Construction

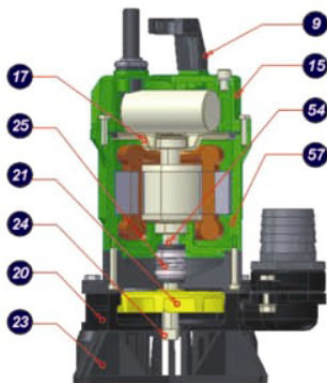

NO.	Parts	Material
9	Handle	Nylon 6
15	Motor Cover	ADC12
17	End Bracket	SECC
20	Pump Casing	FC 200
21	Impeller	TPU
23	Strainer	PVC
24	Agitator	SMF5030
25	Mech. Seal	SIC/SIC
54	Shaft	SUS 410
57	Motor Housing	ADC 12

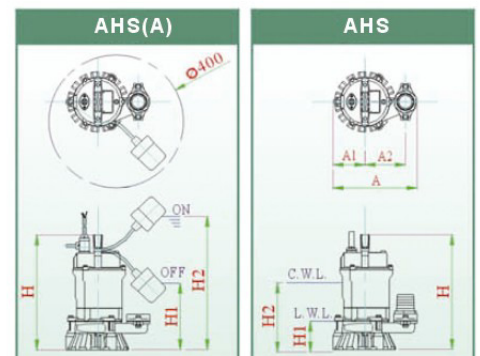

Specification

MODEL	VERSION	OUTPUT		DISCHARGE		RATED		MAXIMUM		DIMENSIONS (mm)						CABLE
		HP	W	mm	inch	head	capacity	head	capacity	A	A ₁	A ₂	H	H ₁	H ₂	
AHS-05	Manual	1/2	400	50	2"	8	110	12	220	249	95	120	343	90	200	5
AHS-05A	Auto	1/2	400	50	2"	8	110	12	220	249	95	120	343	200	400	5
AHS-10	Manual	1	750	50(80)	2"(3")	10	200	18	350	279	95	135	368	90	225	5
AHS-10A	Auto	1	750	50(80)	2"(3")	10	200	18	350	279	95	135	368	225	425	5