



# Double Stage Stainless Steel Pump



Stainless Steel Impeller



## Parts list

No.	Description	Material	O'ty
1	Motor Housing	Aluminum	1
2	Rotor & shaft	SUS 410	1
3	Stator		
4	Terminal Box (lower)	ABS	1
5	Terminal Box (upper)	ABS	1
6	Support Ring	SUS 304	1
7	Pump Head	SUS 304	1
8	Impeller	SUS 304	1
9	Diffuser Plat	SUS 304	1
10	Impeller	SUS 304	1
11	Diffuser	SUS 304	1
12	Support Plate	SUS 304	1
13	Sleeve 23*7L	SUS 304	1
14	Key 4-4*48L	SUS 304	1
15	Mechanical Seal	CE/CA	1
16	Mid Plate	SUS 304	1
17	Front Endshield	Aluminum	1
18	Bearing 6304z		1
19	Bearing 6204z		1
20	Endshield	FC-20	1
21	Centrifugal Switch		1
22	Fan	NYLON 66	1
23	Fan Cover	STEEL	1
24	Washer M10	SUS304	1
25	Nut M10	SUS 304	1
26	O-ring	NBR	1
27	O-ring	NBR	1

## Specifications

TYPE	POWER		DISCHARGE	SUCTION	VOLTAGE	MAXIMUM		DIMENSION (mm)				WEIGHT
	HP	KW	INCH	INCH		50Hz	Head(M)	Q(LPM)	A	B	C	D
250DSE-150	1-1/2	1.1	1	1 1/4"	1PH/220V-240V or 3PH/380V-415V	45	140	319	230	124	435	25
250DSE-200	2	1.5	1	1 1/4"		58	160	319	230	124	435	26.5

## Construction

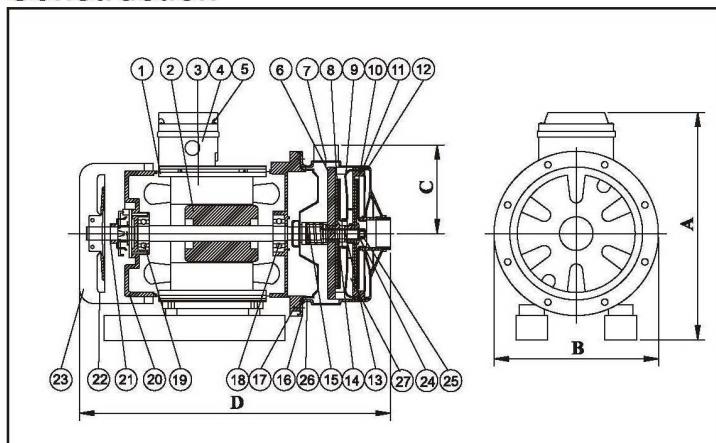

## Performance curve

