

KAT.NMST.02.14.ENG

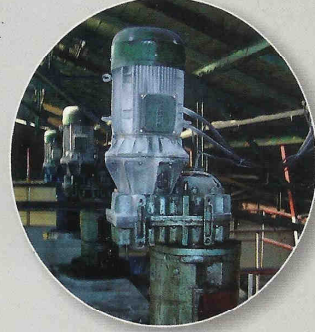

ELSAN ELEKTRİK SAN. ve TİC. A.Ş.



**NORM ELECTRIC MOTORS
THREE PHASES
SQUIRREL CAGE
TEFC
NMST 90 - 355**

IMPORTANT NOTE:

- Due to the continuous development policy, our company reserves the right to make changes the values, dimensions and constructions on this document and to invalidate this document at any time with or without any notice in advance. In no case shall our company is not liable for any possible loss of revenue or profit.

- Please visit our web site (www.elsanas.com.tr or www.emtas.com.tr) for the current dimensions and values.

CERTIFICATES

QUALITY MANAGEMENT SYSTEM



TÜRK STANDARDLARI ENSTİTÜSÜ
TURKISH STANDARDS INSTITUTION

KALİTE YÖNETİM SİSTEMİ BELGESİ

QUALITY MANAGEMENT SYSTEM CERTIFICATE

Partner of



TÜRK STANDARDLARI ENSTİTÜSÜ
bu belge ile

ELSAN ELEKTRİK SANAYİ VE TİC. A.Ş.
ETİLER MAH. 1458 SOK. NO:40 ETİMESGÜT -
ANKARA / TÜRKİYE

Kuruluşunun TS EN ISO 9001:2008 şartlarına uygun bir KALİTE YÖNETİM SİSTEMİNE sahip olduğunu onaylar.

Belge kapsamı Ek'te verilmiştir



TÜRK STANDARDLARI ENSTİTÜSÜ
TURKISH STANDARDS INSTITUTION
Ankara Belgelendirme Müdürlüğü
Ankara Certification Director

A. TÜRKEK
Aydın TÜRKEL

TURKISH STANDARDS INSTITUTION
hereby certifies that the organization

ELSAN ELEKTRİK SANAYİ VE TİC. A.Ş.
ETİLER MAH. 1458 SOK. NO:40 ETİMESGÜT -
ANKARA / TÜRKİYE

has a QUALITY MANAGEMENT SYSTEM which fulfills the requirements of the TS EN ISO 9001:2008.

Scope of the certificate is given in annex

Belge No / Certificate No KY-4285-06/10-R
Belge Tarihi / Date of Certificate 18.11.2013
Geçerlilik Tarihi / Valid Until 18.11.2016
Revizyon Tarihi / Date of Revision 18.11.2013

Türk Standardları Enstitüsü Türk Akreditasyon Kurumu TÜRKAK tarafından akredite edilmiştir.
Turkish Standards Institution, has been accredited by the Turkish Accreditation Agency TÜRKAK.

Bu belge belgelenecek performansa uygunluk sağlandığı sürece geçerlidir. The certificate is valid provided that compliance with the certification requirement is maintained.

TESTING LABORATORY



TÜRK STANDARDLARI ENSTİTÜSÜ
TURKISH STANDARDS INSTITUTION

DENEY HİZMETİ ALINABİLECEK LABORATUVAR ONAYI

SUBCONTRACTOR LABORATORY APPROVAL

TÜRK STANDARDLARI ENSTİTÜSÜ bu belge ile
TURKISH STANDARDS INSTITUTION approves that

ETİLER MAH. 1458 SOK. NO: 40 ETİMESGÜT ANKARA

adresinde faaliyet gösteren
ELSAN ELEKTRİK SANAYİ VE TİCARET A.Ş.

laboratuvarının TSE Deney Hizmeti Alınabilecek Laboratuvar Kriterlerine ve diğer ilgili TSE Mevzuatına göre, kapsamda belirtilen deneyleri yapmaya yeterli bulunduğunu onaylar.

Issued compliant according to TSE Subcontractor Laboratory Criteria and the other relevant TSE regulations, related with tests stated in the scope.

Numarası / Number : 06/55
Veriliş Tarihi / Date of Issue : 11.10.2005
Geçerlilik Tarihi / Valid Until : 03.02.2016

30.01.2014

Bünye ÇAKIR
ANKARA HİZMET YERİ BELGELENDİRME
MÜDÜRÜ

Sayfa / Page : 1 / 1

Bu doküman laboratuvarın TS EN ISO/IEC 17025'e göre belgelendirildiği/akredite edildiği anlamını taşımaz ve bu amaçla kullanılamaz.
This document alone not means that the laboratory is certified / accredited according to TS EN ISO/IEC 17025 and cannot be used for this purpose.



TÜRK STANDARDLARI ENSTİTÜSÜ
TURKISH STANDARDS INSTITUTION

DENEY HİZMETİ ALINABİLECEK LABORATUVAR KAPSAMI

SUBCONTRACTOR LABORATORY APPROVAL SCOPE

Firma Adı / Company Name : ELSAN ELEKTRİK SANAYİ VE TİCARET A.Ş. Numarası / Number : 06/55

Veriliş Tarihi / Date of Issue : 11.10.2005

Geçerlilik Tarihi / Valid Until : 03.02.2016

TS EN ISO / IEC 17025 "Deney ve Kalibrasyon Laboratuvarlarının Yeterliliği İçin Genel Şartlar" Standardı Referans Alınarak Yapılan İnceleme Kapsamı aşağıda verilmiştir:
Scope of the audit that is conducted by the reference of TS EN ISO / IEC 17025 "General requirements for the competence of testing and calibration laboratories" is given below:

Grün Adı	Deney Adı	Standart No / Method
Çalışma Performansı / Schmeisba Rume	Performans Deneyi / Performance Test	TSE 18146
Aşırı Akım Motor / Polyphase Induction Motor	Çizgi Yöntemi / Resistance Method	IEC 60034-1) 9.8.2
Aşırı Akım Motor / Polyphase Induction Motor	Ruğun Deneyler - Açık Devre Durumunda Ölçülme (SOLU) / Routine Tests - Resistance of windings (cold)	IEC 60034-1) 9.1 Tablo 15 Number 2
Aşırı Akım Motor / Polyphase Induction Motor	Ruğun Deneyler - Boşlu Kayıt Akım / Routine Tests - No-load losses and current	IEC 60034-1) 9.1 Tablo 15 Number 3b
Aşırı Akım Motor / Polyphase Induction Motor	Ruğun Deneyler - Makine Dururken Açık Devre Beklenilen Gerilimlerin Belirleme / Routine Tests - Open Circuit Secondary Induced Voltage at Standstill (Wound Rotor)	IEC 60034-1) 9.1 Tablo 15 Number 5
Aşırı Akım Motor / Polyphase Induction Motor	Dayanım Gerilimi Deneyi / Withstand Voltage Test Table 16 Item 2	IEC 60034-1) 9.2 Test Table 16 Item 2
Aşırı Akım Motor / Polyphase Induction Motor	Azaltıcı Çığır Açın Akım / Decreasing Excitation Current	IEC 60034-1) 9.3
Aşırı Akım Motor / Polyphase Induction Motor	Momentane Anlık Akımın Belirleme / Momentary Short-circuit test (S.C.T) / Momentary Excess Torque for Motors (S.4) / Polyphase induction motors and d.c. motors (S.4.1)	IEC 60034-1) 9.4 S.4.1

Sayfa / Page : 1 / 1

Bu doküman 192 sayılı kanun gereği ve Türk Standardları Enstitüsü mevzuatı uyarınca verilmiştir, tahrir edilmez, kâğıt veya tamamen okunmasını zorlayacak şekilde çoğaltılamaz.
This document is issued in accordance with the Law No. 192 and regulations of Turkish Standards Institution, can not be reissued and its duplication (copy) cannot be made in any way that affects the reading.

GENERAL INFORMATION

STANDARDS

Motors comply with relevant standards and specifications, especially with:

IEC 60034-1	IEC 60034-2
IEC 60034-5	IEC 60034-6
IEC 60034-7	IEC 60034-8
IEC 60034-9	IEC 60034-12
IEC 60034-14	IEC 60034-15
IEC 60034-18-1	IEC 60072

MECHANICAL CONSTRUCTION

Totally enclosed fan cooled (TEFC) squirrel cage motors are robust in design and construction and are capable of running continuously for prolonged periods with minimum of attention.

All frames have cooling ribs to provide much better cooling, high strength and rigidity.

The feet are screw connected to enable easy replacement and removal (for conversion to flange mounting).

The materials of motor parts are listed the table below.

Parts / Frame Sizes	90	100	112	132	160	180	200	225	250	280	315	355
Frame	Cast Iron [GG20]											
End shields and bearing caps	Cast Iron [GG20]											
Feet	Ductile Iron [GGG50]											
Terminal box and cover	Cast Iron [GG20]				Aluminium				Cast Iron [GG20]			
Shaft	Steel [SAE 1040]											
Fan	Plastic											Alum.
Fan cowl	Steel Sheet											
Cable gland	Plastic										Brass	

VOLTAGE AND FREQUENCY

Motors are produced 380 V - 50 Hz as standard. On request, motors can be produced up to 1100 V.

If a standard motor is run with 380 V - 60 Hz the rated speed is increased 20% and the rated torque is decreased 20%. If the voltage is increased with same ratio the rated speed and the rated output are increased 20% and the rated torque is same.

INSULATION CLASS

280 size and lower motors are "F" insulation. 315 and 355 size motors are "H" insulation. On request, motors can be produced with higher insulation.

TERMINAL BOX

The terminal boxes are located on the right side of motor viewed from the drive end (except 315 and 355 sizes). On request, the terminal boxes can be located on the top or right side.

The terminal box are designed to turn by 180°.

ENCLOSURE

280 size and lower motors are "IP55" protection. 315 and 355 size motors are "IP65" protection. For this reason, motors can be run at dusty and dirty environments.

On request, motors can be produced with higher protection.

280 size and bigger motors have the drain holes at bottom of the frame. The drain holes are closed a tap. If the drain holes are open motors are "IP44" protection.

COOLING

Motors are cooled by a current of cooling air forced over the ribbed stator frame by a bi-directional fan which is mounted on the motor shaft at the non-driving end, and protected by a fan cover. The direction of rotation is not affect the cooling.

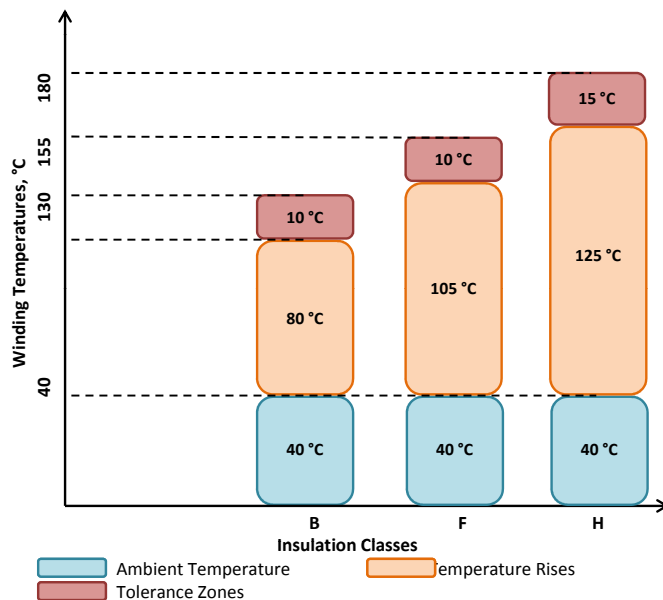

GENERAL INFORMATION

RATED OUTPUT

The rated outputs and operating characteristics given in the tables refer to short time duty (S2 240 min) at a rated frequency of 50 Hz, rated voltage, a maximum ambient temperature of 40°C and an altitude of up to 1000 m above sea level. For operation in different ambient temperatures and/or sea level, the rated output is corrected as follows:

Ambient temperature	30 °C	35 °C	40 °C	45 °C	50 °C	55 °C	60 °C
Derating factor k_1	1,07	1,04	1,00	0,95	0,91	0,86	0,80
Sea level	1000 m	2000 m	3000 m	4000 m	5000 m		
Derating factor k_2	1,00	0,94	0,87	0,80	0,77		

Example:

Rated output 11 kW
 Ambient temperature 45 °C
 Sea level 2000 m

Derated output:

$$P = k_1 \times k_2 \times P_n = 0,95 \times 0,94 \times 11 = 9,82 \text{ kW}$$

THERMAL PROTECTION

Ideally the choice of thermal protection for the stator windings should be based on the operating conditions. Two main methods of protection are available: Current dependent circuit breakers and temperature-dependent semiconductor detectors (thermistors).

Circuit breakers and over-current relays protect the motor against possible damage in cases of occasional overloads, locked rotor or phase failure, whereas thermistors provide a higher degree of protection because the temperature is monitored at the critical point in the winding. Thus protecting the motor against any cause which results in excessive winding heating such as overloads, excessive ambient temperature, unpermissibly high or low voltage, impaired cooling, intermittent operation, high switching frequency, non-sinusoidal wave form, etc. 250 size and bigger motors are fitted with PTC thermistor detectors which are placed at the hot spots in the end-windings, normally one per phase, and connected in series. On request, other motors can be fitted with PTC thermistor.

STARTING

All motors are capable of direct starting when suitable network and other components exist. For the direct starting, the starting torque and the starting current are high.

Against the high starting current, the star/delta starting is preferred for 4 kW and upper motors. For the star/delta starting, the starting torque and the starting current is 1/3 of the values of the direct starting.

All motors are suitable for the soft starter.

FREQUENCY CONVERTER

To decrease the impacts of the frequency converter, the changings are applied:

- Winding with corona strength wire (225 size and bigger)
- Reinforced insulation
- Rotor construction (200 size and bigger)
- Insulated bearing (315 size and bigger)
- Forced ventilation unit (According to the application)

ENCODER

On request, motors are produced with the encoder. The properties of the standard encoder are listed below:

- Incremental type
- "5 VDC" supply
- "TTL Line Driver" output
- Cable 8 poles
- 1024 pulse

The different encoder or customers' encoder are fitted on the motor.

The length of motors with the encoder and/or the forced ventilation unit are increased according to the table below:

Motor Type	Addition of Length, [mm]
NMST 90	95
NMST 100	95
NMST 112	95
NMST 132	70
NMST 160	110
NMST180	105
NMST 200	80
NMST 225	85
NMST 250	300
NMST 280	340
NMST 315/2	340
NMST 315/4	310
NMST 355	330

GENERAL INFORMATION

BEARINGS

All motors are fitted the bearings are carried radial, axial or combine loads and generously sized to ensure long life. For the bearings types of various frame sizes see the table below. On request, motors can be delivered with cylindrical roller bearings at the drive end.

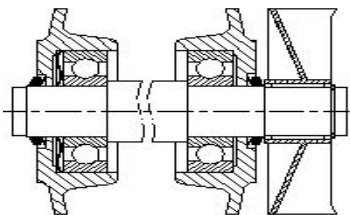
Motor Type	Number of Poles	Drive End [DE]		Non-Drive End [NDE]	Mounting Type
		Ball	Roller		
NMST 90	2-4-6-8	6205 ZZ	-	6205 ZZ	
NMST 100	2-4-6-8	6206 ZZ	-	6206 ZZ	
NMST 112	2-4-6-8	6306 ZZ	-	6306 ZZ	
NMST 132	2-4-6-8	6308 ZZ	-	6308 ZZ	
NMST 160	2-4-6-8	6309 ZZ	-	6309 ZZ	
NMST180	2-4-6-8	6310 ZZ	-	6310 ZZ	
NMST 200	2-4-6-8	6313 ZZ	-	6313 ZZ	
NMST 225	2	6313 2RS	-	6313 2RS	
	4-6-8	6314	NU 314	6314	
NMST 250	2	6314 2RS	-	6314 2RS	
	4-6-8	6315	NU 315	6314	
NMST 280	2	6316 2RS	-	6316 2RS	
	4-6-8	6317	NU 317	6316	
NMST 315	2	6316 2RS	-	6316 2RS	
	4-6-8	6319	NU 319	6318	
NMST 315L	4-6-8	6321	NU 321	6318	
NMST 355	4-6-8	6322	NU 322	6321	

PERMISSIBLE RADIAL LOADS

MOTOR TYPE	F_R [N]							
	2 poles - 3000 rpm		4 poles - 1500 rpm		6 poles - 1000 rpm		8 poles - 750 rpm	
	$X = X_0$	$X = X_{max}$	$X = X_0$	$X = X_{max}$	$X = X_0$	$X = X_{max}$	$X = X_0$	$X = X_{max}$
NMST 90	577	458	785	623	898	713	998	793
NMST 100	899	731	1.115	907	1.273	1.035	1.415	1.151
NMST 112	1.283	1.041	1.604	1.302	1.837	1.490	2.039	1.654
NMST 132	1.861	1.460	2.321	1.867	2.654	2.136	2.994	2.409
NMST 160	2.346	1.877	3.009	2.407	3.449	2.760	3.790	3.033
NMST 180	2.793	2.245	3.458	2.779	4.014	3.226	4.402	3.538
NMST 200	4.086	3.382	5.091	4.221	6.054	5.020	6.642	5.507
NMST 225	3.990	3.329	5.599	4.514	6.449	5.146	7.200	5.745
NMST 250	4.430	3.618	5.980	4.884	6.991	5.710	7.737	6.320
NMST 280	4.972	4.228	6.797	5.810	7.608	6.504	8.962	7.661
NMST 315	3.998	3.381	6.735	5.683	8.400	7.087	9.164	7.731
NMST 355	-	-	8.571	7.142	10.548	8.790	11.894	9.912

Note: The permissible radial and axial load values are calculated according to 25.000 operating hours at 50 Hz. These values must be decreased by 30% for 40.000 operating hours and must be decreased by 10% for 60 Hz.

GENERAL INFORMATION

PERMISSIBLE AXIAL LOADS

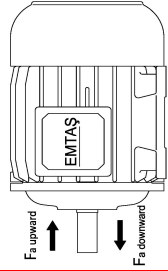
MOTOR TYPE	HORIZONTAL MOTOR (B3)				VERTICAL MOTOR (V5) - SHAFT DOWNWARD			
								
	$F_{a \text{ outward}} [N]$	$F_{a \text{ inward}} [N]$	$F_{a \text{ outward}} [N]$	$F_{a \text{ inward}} [N]$	$F_{a \text{ downward}} [N]$	$F_{a \text{ upward}} [N]$	$F_{a \text{ downward}} [N]$	$F_{a \text{ upward}} [N]$
$F_R = 0$		$F_R = \text{max}$		$F_R = 0$		$F_R = \text{max}$		
2 poles - 3000 rpm								
NMST 90	160	450	160	400	130	490	130	405
NMST 100	210	720	210	570	165	675	165	575
NMST 112	220	1.100	220	920	160	1.085	160	905
NMST 132	340	1.600	340	1.310	230	1.595	230	1.315
NMST 160	350	2.020	350	1.680	*	2.290	*	1.960
NMST 180	425	2.310	425	1.965	*	2.725	*	2.315
NMST 200	430	3.650	430	3.160	*	4.240	*	3.755
NMST 225	4.050	4.050	1.925	1.925	3.540	4.760	1.585	2.815
NMST 250	4.510	4.510	2.350	2.350	3.855	5.450	1.670	3.270
NMST 280	5.100	5.100	2.650	2.650	4.130	6.575	1.600	4.045
NMST 315	4.630	4.630	2.650	2.650	2.795	7.505	745	5.455
4 poles - 1500 rpm								
NMST 90	160	665	160	605	120	715	120	580
NMST 100	210	875	210	790	145	945	145	820
NMST 112	220	1.550	220	1.280	130	1.520	130	1.265
NMST 132	340	2.230	340	1.830	160	2.225	160	1.895
NMST 160	350	2.750	350	2.350	*	3.160	*	2.710
NMST 180	425	3.175	425	2.715	*	3.755	*	3.230
NMST 200	430	4.950	430	4.250	*	5.790	*	5.160
NMST 225	5.960	5.960	3.100	3.100	5.160	7.135	2.215	4.190
NMST 250	6.330	6.330	3.355	3.355	5.530	7.965	2.320	4.760
NMST 280	6.770	6.770	3.550	3.550	5.225	8.935	2.095	5.805
NMST 315	7.150	7.150	4.200	4.200	4.310	11.495	1.170	8.350
NMST 355	8.020	8.020	4.520	4.520	4.010	13.310	*	10.080
6 poles - 1000 rpm								
NMST 90	160	820	160	730	110	860	110	725
NMST 100	210	1.055	210	1.000	125	1.165	125	1.010
NMST 112	220	1.860	220	1.565	110	1.810	110	1.540
NMST 132	340	2.680	340	2.230	130	2.670	130	2.300
NMST 160	350	3.360	350	2.850	*	3.800	*	3.275
NMST 180	425	3.915	425	3.305	*	4.465	*	3.840
NMST 200	430	7.450	430	5.160	*	6.835	*	6.025
NMST 225	6.900	6.900	3.600	3.600	6.220	8.385	2.685	4.855
NMST 250	7.770	7.770	3.950	3.950	6.960	9.540	2.845	5.430
NMST 280	7.920	7.920	4.210	4.210	6.005	10.800	2.300	7.100
NMST 315	8.510	8.510	4.900	4.900	5.945	12.855	2.300	9.220
NMST 355	9.330	9.330	5.210	5.210	5.120	14.910	*	11.110
8 poles - 750 rpm								
NMST 90	160	920	160	830	110	975	110	815
NMST 100	210	1.240	210	1.130	125	1.345	125	1.120
NMST 112	220	2.160	220	1.790	110	2.085	110	1.750
NMST 132	340	3.010	340	2.600	150	2.960	150	2.565
NMST 160	350	3.760	350	2.890	*	4.245	*	3.755
NMST 180	425	4.375	425	3.740	*	4.995	*	4.415
NMST 200	430	6.820	430	5.910	*	7.680	*	6.765
NMST 225	8.030	8.030	4.060	4.060	7.165	9.335	3.155	5.320
NMST 250	8.550	8.550	4.455	4.455	7.580	10.315	3.315	6.050
NMST 280	9.230	9.230	4.800	4.800	7.575	11.620	3.175	7.220
NMST 315	9.700	9.700	5.500	5.500	6.910	14.590	2.370	10.050
NMST 355	10.400	10.400	5.760	5.760	6.020	16.240	*	11.950

* Please consult our company for these values.

GENERAL INFORMATION

SHAFT

Motor are normally produced with one shaft. On request, a second shaft extension or a special shaft extensions can be provided.

Motor are delivered with key mounted.

BALANCE

The rotating parts of the motor (shaft, rotor and aluminium fan) are dynamically balanced with an half key.

CONSTRUCTION TYPES

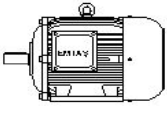
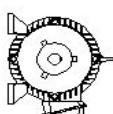
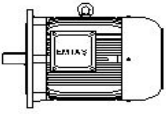
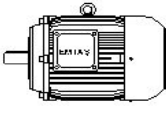
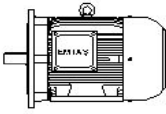
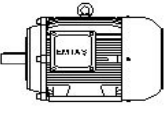
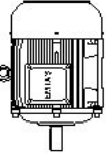
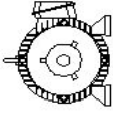
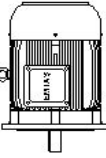
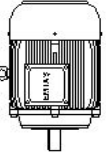
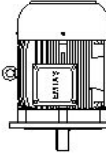
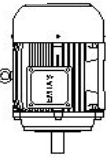
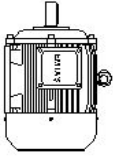
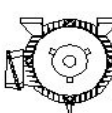
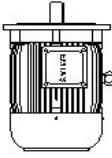
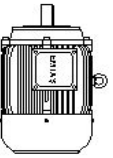
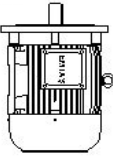
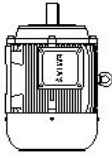
FOOT MOUNTING		FLANGE MOUNTING		FOOT AND FLANGE MOUNTING	
		B5 (A) - FLANGE	B14 (C) - FLANGE	B5 (A) - FLANGE	B14 (C) - FLANGE
B3 	B6 	B5 	B14 	B3/B5 	B3/B14 
V5 	B7 	V1 	V18 	V1/V5 	V18/V5 
V6 	B8 	V3 	V19 	V3/V6 	V19/V6 

ORDERING INFORMATION

Necessary Information:

Rated output [kW]
Synchronous speed or rated speed [rpm]
Position of terminal box

The standard values are listed in the table on the side for information is not taken.

Optional Information:

Construction type : B5 flange, B14 flange etc.
Frame size : 160 type, 180 type etc.
Voltage : 400 V, 550 V etc.
Frequency : 60 Hz, 70 Hz, etc.
Starting method : Direct on line, soft starter, frequency converter etc.
Protection class : IP56, IP65 etc.
Insulation class : H etc.
Duty type : S3 %60 etc.
Ambient temperature : 50 °C, 60 °C etc.
Radial/Axial loads : 600 kg etc.
Other properties : Two shaft extensions etc.

Standard Values for Information Is Not Taken:

Information	Standard Values
Construction type	B3 foot mounting
Frame size	See Page-9 ve 10
Length of feet	See Page-9 ve 10
Voltage	380 V
Frequency	50 Hz
Starting method	See Page-3
Protection class	See Page-2
Insulation class	See Page-2
Duty type	S2 240 min
Ambient temperature	40 °C
Radial/Axial loads	See Page-4 ve 5
Shaft extension	See Page-6, 11, 12 ve 13
Terminal box location	See Page-2
Material of motor parts	See Page-2
DE/NDE bearing	See Page-4

GENERAL INFORMATION

MOTOR LOAD (TORQUE-SPEED) CURVE

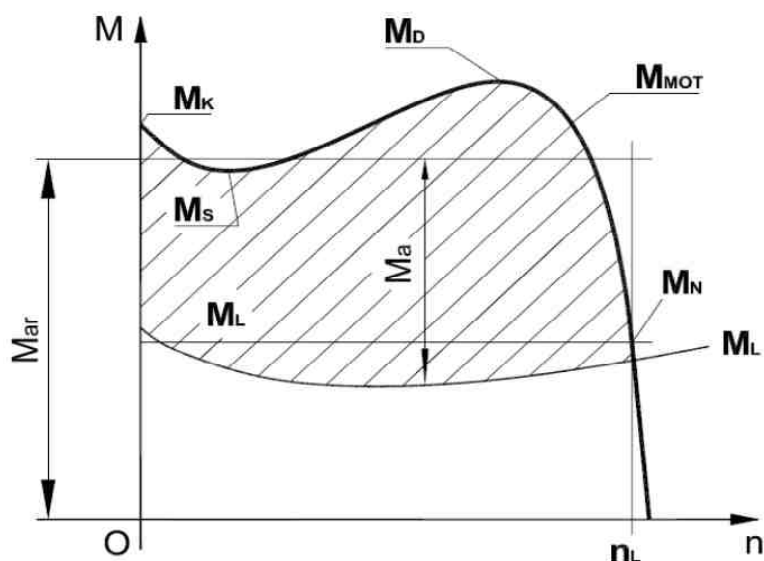

- M_K - Starting Torque
- M_S - Pull up Torque
- M_D - Breakdown Torque
- M_N - Rated Torque
- M_L - Load Torque
- M_{ar} - Average Torque of Acceleration Torque
- M_a - Acceleration Torque
- n_L - Rated Speed
- M_{MOT} - Motor Torque

TOLERANCES ON PERFORMANCE DATA

IEC 60034-1 specifies the following standard tolerances for electro mechanical characteristics.

Parameters	Tolerances IEC 60034-1
Efficiency	
Method of indirect determination	
- $P_N \leq 150$ kW	$\frac{-(1-\eta) \cdot 15}{100}$
- $P_N > 150$ kW	$\frac{-(1-\eta) \cdot 10}{100}$
Direct measurement	$\frac{-(1-\eta) \cdot 15}{100}$
Power Factor (Cos φ)	Min 0,02 Max 0,07
Slip (at full load and at working temperature)	
- $P_N < 1$ kW	± 30 %
- $P_N \geq 1$ kW	± 20 %
Starting Current, (I_k)	+20 %
Starting Torque, (M_k)	+25 % -15 %
Breakdown Torque, (M_D)	-10 % (Even after deducting this tolerance, the breakdown torque must not be lower than 1,6 times the rated torque.)

FORMULAS

FORMULAS FOR ELECTRIC MOTORS

As the load is increased, the actual speed n of an induction motor falls from its initial no-load speed which is effectively the synchronous speed n_{syn} . The slip in % is defined as:

$$n_{syn} = \frac{120 \cdot f}{p} \quad s = \frac{n_{syn} - n}{n_{syn}}$$

n : Asynchronous speed [rpm]
 n_{syn} : Synchronous speed [rpm]
 f : Supply frequency [Hz]
 p : Number of poles
 s : slip [%]

	SI	MKS
P : Rated output	[kW]	[PS]
U : Supply voltage	[V]	[V]
I : Current per phase	[A]	[A]
Cos ϕ : Power factor	-	-
η : Efficiency	%	%

$$P = \frac{\sqrt{3} \cdot U \cdot I \cdot \cos \phi \cdot \eta}{1000} \quad [\text{kW}]$$

$$P = \frac{1.36 \cdot \sqrt{3} \cdot U \cdot I \cdot \cos \phi \cdot \eta}{1000} \quad [\text{PS}]$$

BELT-PULLEY SYSTEM

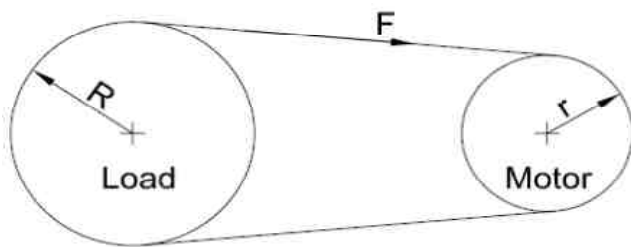

$$M = F \cdot r \quad [\text{Nm}] \quad M = F \cdot r \quad [\text{kgfm}]$$

$$P = \frac{M \cdot n}{9550} \quad [\text{kW}] \quad P = \frac{M \cdot n}{716} \quad [\text{PS}]$$

	SI	MKS
P : Rated output	[kW]	[PS]
M : Torque	[Nm]	[kgfm]
F : Force	[N]	[kgf]
r : Radius arm	[m]	[m]
n : Asynchronous speed	[rpm]	[rpm]

$$1 \text{ kW} = 1,36 \text{ PS}$$

$$1 \text{ Nm} = 0,102 \text{ kgfm}$$

$$1 \text{ N} = 0,102 \text{ kgf}$$

MOTOR CHARACTERISTICS AND STARTING TIME

	SI	MKS
t_a : Starting time	[sn]	[sn]
J, GD ² : Moment of inertia	[kgm ²]	[kgfm ²]
n : Speed	[1/dak.]	[d/dak.]
M : Torque	[Nm]	[kgfm]
i : Gear ratio		

$$t_a = \frac{J \cdot n}{9,55 \cdot M_a} \quad t_a = \frac{GD^2 \cdot n}{375 \cdot M_a}$$

$$M_a = M_{ar} - M_L \quad M_a = M_{ar} - M_L$$

J_{mot} : Moment of inertia of motor (Please refer to Performance Data charts)

Please refer to page 7 for M_a , M_{ar} and M_L

$$J = \frac{J_{load}}{i^2} + J_{mot} \quad GD^2 = \frac{GD^2_{load}}{i^2} + GD^2_{mot}$$

PERFORMANCE DATA

3000 rpm																		2 POLES						380 V			50 Hz	
TYPE	Rated Output		Rated Current	Rated Speed	Power Factor				Efficiency				Rated Torque	Starting Current	Starting Torque	Breakdown Torque	Moment of Inertia	Weight										
	Frame Size	kW	PS	I _N A	n rpm	Cos φ				η				M _N Nm	I _k /I _N	M _k /M _N	M _D /M _N	J _{MOT} kgm ²	kg									
						%125	%100	%75	%50	%125	%100	%75	%50															
NMST 90S2	1,5	2	3,3 λ	2837	0,91	0,89	0,85	0,76	75,0	77,3	78,3	80,1	5,1	5,0	2,3	2,5	0,0013	20										
NMST 90L2	2,2	3	4,7 λ	2839	0,91	0,89	0,84	0,74	75,7	79,8	82,3	85,1	7,4	5,4	2,4	2,8	0,0016	22										
NMST 100L2	3	4	6,6 λ	2865	0,87	0,84	0,79	0,69	81,6	81,7	85,2	79,6	10,0	5,9	2,8	2,9	0,0027	29										
NMST 112M2	4	5,5	8,0 Δ	2872	0,92	0,91	0,88	0,82	84,8	83,3	87,0	87,2	13,3	6,5	2,5	2,6	0,0048	42										
NMST 132S2	5,5	7,5	11,3 Δ	2886	0,88	0,87	0,83	0,75	85,3	84,9	86,9	84,9	18,2	6,3	2,7	2,8	0,0099	60										
NMST 132S2	7,5	10	15,0 Δ	2877	0,90	0,88	0,84	0,75	85,5	86,1	87,6	85,5	24,9	6,8	3,0	3,0	0,0123	66										
NMST 160M2	11	15	22,3 Δ	2934	0,86	0,85	0,80	0,73	87,8	88,0	87,8	85,1	35,8	6,7	2,9	2,8	0,0274	110										
NMST 160M2	15	20	29,2 Δ	2923	0,89	0,88	0,85	0,78	88,4	88,7	90,3	88,9	49,0	6,3	2,8	3,2	0,0339	120										
NMST 160Lb2	18,5	25	34,6 Δ	2930	0,92	0,91	0,89	0,86	87,8	89,4	88,9	90,6	60,3	7,0	3,0	3,2	0,0435	140										
NMST 180M2	22	30	41,3 Δ	2926	0,90	0,90	0,79	0,85	89,1	89,9	88,5	88,5	71,8	6,8	2,6	3,2	0,0593	175										
NMST 200L2	30	40	55,7 Δ	2945	0,90	0,90	0,90	0,87	88,8	91,0	90,7	87,9	97,3	7,0	2,6	2,9	0,1089	245										
NMST 200L2	37	50	68,5 Δ	2962	0,90	0,90	0,89	0,85	91,6	91,2	91,4	89,0	119,3	7,1	2,6	2,8	0,1300	265										
NMST 225M2	45	60	82,8 Δ	2962	0,90	0,90	0,89	0,84	92,4	91,7	90,6	90,5	145,1	7,0	2,5	2,8	0,1983	330										
NMST 225Md2	55	75	99,3 Δ	2957	0,90	0,91	0,90	0,86	90,2	92,5	90,9	90,7	177,6	6,7	2,5	2,6	0,2424	360										
NMST 250M2	55	75	99,2 Δ	2964	0,90	0,91	0,90	0,85	92,0	92,6	92,9	91,5	177,2	7,2	2,3	2,8	0,3241	440										
NMST 250M2	75	100	134,9 Δ	2963	0,90	0,91	0,90	0,87	90,5	92,8	92,7	91,7	241,7	7,0	2,5	2,8	0,3624	485										
NMST 280S2	75	100	139,7 Δ	2973	0,87	0,88	0,87	0,82	92,1	92,7	92,2	92,7	240,9	6,5	2,0	2,7	0,5154	560										
NMST 280Ma2	90	125	165,2 Δ	2978	0,88	0,89	0,88	0,85	93,0	93,3	93,5	92,5	288,6	7,5	2,1	2,9	0,6171	620										
NMST 280Mc2	110	150	205,9 Δ	2977	0,88	0,87	0,86	0,81	94,6	93,3	93,0	91,0	352,9	7,5	2,3	2,7	0,7187	700										
NMST 315S2	110	150	201,1 Δ	2976	0,87	0,89	0,90	0,89	92,1	93,4	92,1	88,9	353,0	6,8	1,8	2,9	1,3176	740										
NMST 315Ma2	132	180	235,7 Δ	2975	0,90	0,91	0,92	0,90	93,3	93,5	92,8	91,3	423,7	6,8	1,8	2,8	1,4160	840										
NMST 315M2	160	220	285,1 Δ	2976	0,91	0,91	0,90	0,88	93,4	93,7	94,4	92,2	513,4	7,0	1,8	2,6	1,5606	900										
NMST 315L2	185	250	325,0 Δ	2975	0,92	0,92	0,92	0,89	92,9	94,0	93,4	92,1	593,9	7,0	1,9	2,5	1,7727	1120										
NMST 315L2	200	270	346,5 Δ	2980	0,93	0,93	0,92	0,89	93,5	94,3	93,7	91,7	640,9	7,5	2,1	2,4	1,8910	1160										
NMST 315Ld2	250	340	436,9 Δ	2980	0,92	0,92	0,90	0,86	93,5	94,5	94,6	91,9	801,2	7,5	2,0	2,2	2,3053	1250										

1500 rpm																		4 POLES						380 V			50 Hz	
TYPE	Rated Output		Rated Current	Rated Speed	Power Factor				Efficiency				Rated Torque	Starting Current	Starting Torque	Breakdown Torque	Moment of Inertia	Weight										
	Frame Size	kW	PS	I _N A	n rpm	Cos φ				η				M _N Nm	I _k /I _N	M _k /M _N	M _D /M _N	J _{MOT} kgm ²	kg									
						%125	%100	%75	%50	%125	%100	%75	%50															
NMST 90S4	1,1	1,5	2,7 λ	1401	0,86	0,83	0,75	0,63	71,0	75,5	75,5	74,3	7,5	4,3	2,3	2,4	0,0022	18										
NMST 90L4	1,5	2	3,6 λ	1418	0,86	0,82	0,75	0,62	72,0	77,4	80,0	81,3	10,1	5,0	2,4	2,6	0,0028	22										
NMST 100L4	2,2	3	5,2 λ	1420	0,84	0,80	0,72	0,58	80,5	79,9	79,6	77,5	14,8	5,3	2,4	2,6	0,0043	29										
NMST 100L4	3	4	7,0 λ	1425	0,84	0,80	0,72	0,59	78,8	81,5	82,6	82,5	20,1	6,0	2,5	2,8	0,0055	32										
NMST 112M4	4	5,5	9,0 Δ	1425	0,86	0,81	0,73	0,60	81,9	83,1	82,6	82,7	26,8	6,0	2,6	2,9	0,0103	45										
NMST 132S4	5,5	7,5	11,6 Δ	1416	0,87	0,85	0,80	0,69	81,9	84,8	86,3	85,3	37,1	6,0	2,4	2,8	0,0221	65										
NMST 132M4	7,5	10	15,6 Δ	1430	0,87	0,85	0,81	0,72	83,1	86,0	87,6	88,4	50,1	6,2	2,4	2,8	0,0291	77										
NMST 160M4	11	15	22,7 Δ	1463	0,86	0,84	0,79	0,69	84,5	87,8	87,0	87,6	71,8	6,3	2,5	2,8	0,0553	116										
NMST 160Lb4	15	20	30,5 Δ	1465	0,87	0,84	0,79	0,68	88,9	88,9	88,9	86,9	97,8	6,9	2,7	2,9	0,0730	136										
NMST 180M4	18,5	25	37,0 Δ	1459	0,86	0,85	0,81	0,73	86,7	89,3	87,8	87,8	121,1	6,2	2,8	2,9	0,1074	173										
NMST 180Lb4	22	30	43,7 Δ	1463	0,86	0,85	0,82	0,74	88,7	90,0	89,3	88,0	143,6	6,6	2,8	2,8	0,1285	193										
NMST 200L4	30	40	57,1 Δ	1470	0,89	0,88	0,84	0,76	90,5	90,7	91,3	88,7	194,9	6,5	2,5	2,8	0,2069	256										
NMST 200L4	37	50	70,0 Δ	1472	0,89	0,88	0,84	0,77	91,1	91,2	92,3	89,6	240,0	7,0	2,6	2,7	0,2682	280										
NMST 225S4	37	50	69,2 Δ	1472	0,90	0,89	0,87	0,80	90,5	91,3	92,1	91,4	240,0	6,6	2,7	2,7	0,3526	300										
NMST 225M4	45	60	82,8 Δ	1472	0,91	0,90	0,87	0,81	91,1	91,8	92,0	91,0	292,0	6,6	2,7	2,8	0,4195	370										
NMST 225Md4	55	75	103,0 Δ	1470	0,90	0,88	0,84	0,75	91,6	92,2	92,4	91,0	357,3	6,8	2,5	2,7	0,4735	390										
NMST 250M4	55	75	102,9 Δ	1478	0,90	0,88	0,84	0,78	92,0	92,3	92,3	91,9	355,4	6,8	2,9	2,8	0,6045	440										
NMST 250M4	75	100	142,9 Δ	1475	0,89	0,86	0,82	0,74	92,7	92,7	92,8	92,6	485,6	7,0	3,0	2,7	0,7316	500										
NMST 280S4	75	100	139,5 Δ	1480	0,89	0,88	0,85	0,76	93,3	92,8	93,5	93,5	484,0	7,0	2,8	2,6	0,9400	600										
NMST 280Ma4	90	125	167,1 Δ	1476	0,88	0,88	0,84	0,76	93,4	93,0	94,1	93,7	582,3	6,7	2,2	2,6	1,1499	670										
NMST 280Ma4	110	150	203,6 Δ	1478	0,88	0,88	0,86	0,81	91,7	93,3	93,9	92,4	710,8	6,7	2,4	2,4	1,3689	770										
NMST 315S4	110	150	205,9 Δ	1488	0,87	0,87	0,86	0,79	92,5	93,3	91,9	90,6	706,0	6,0	1,8	2,4	1,8827	830										
NMST 315Ma4	132	180	243,7 Δ	1488	0,89	0,88	0,85	0,77	94,1	93,5	92,6	90,7	847,0	7,0	2,1	2,4	2,2195	930										
NMST 315Ma4	160	220	294,2 Δ	1488	0,89	0,88	0,86	0,78	93,3	93,9	94,0	92,3	1027,0	7,0	2,0	2,3	2,6236	1030										
NMST 315Lb4	185	250	338,0 Δ	1488	0,89	0,88	0,85	0,76	95,4	94,5	92,7	92,7	1187,0	7,2	2,1	2,1	3,0349	1100										
NMST 315Lb4	200	270	353,4 Δ	1489	0,91	0,91	0,90	0,85	93,8	94,5	93,9	93,6	1283,0	7,5	2,0	2,2	3,3044	1150										
NMST 315L4	250	340	449,2 Δ	1490	0,89	0,89	0,88	0,83	94,5	95,0	93,8	91,9	1602,3	7,0	2,0	2,0	4,0594	1200										
NMST 355S4	250	340	436,9 Δ	1489	0,91	0,92	0,91	0,86	91,7	94,5	94,7	97,4	1603,0	6,5	1,9	2,2	4,6266	1420										
NMST 355S4	315	430	547,6 Δ	1490	0,92	0,92	0,90	0,84	92,2	95,0	95,1	90,3	2019,0	7,3	1,9	2,2	6,4202	1765										
NMST 355L4	355	485	623,9 Δ	1490	0,91	0,91	0,89	0,83	91,9	95,0	93,6	94,2	2275,3	7,3	2,0	2,2	7,1662	1900										
NMST 355L4	400	544	710,8 Δ	1490	0,91	0,90	0,87	0,79	91,2	95,0	93,0	91,4	2563,8	7,5	2,0	2,2	8,2423	2060										

Please visit our web site (www.elsanas.com.tr or www.emtas.com.tr) for the current dimensions and values.

PERFORMANCE DATA

1000 rpm		6 POLES										380 V		50 Hz				
TYPE	Rated Output		Rated Current	Rated Speed	Power Factor				Efficiency				Rated Torque	Starting Current	Starting Torque	Breakdown Torque	Moment of Inertia	Weight
Frame Size	kW	PS	I _N A	n rpm	Cos φ				η				M _N Nm	I _k /I _N	M _k /M _N	M _b /M _N	J _{MOT} kgm ²	kg
					%125	%100	%75	%50	%125	%100	%75	%50						
NMST 90S6	0,75	1	2,3 λ	907	0,76	0,72	0,63	0,50	65,3	70,0	75,8	75,2	7,9	3,4	1,9	2,0	0,0035	18
NMST 90L6	1,1	1,5	3,1 λ	906	0,77	0,74	0,66	0,55	69,3	72,9	76,1	51,8	11,6	3,8	2,0	2,2	0,0045	21
NMST 100L6	1,5	2	4,0 λ	930	0,77	0,74	0,66	0,55	77,2	77,2	80,6	77,1	15,4	4,8	2,0	2,2	0,0094	30
NMST 112M6	2,2	3	5,6 λ	938	0,81	0,76	0,68	0,55	76,5	78,0	80,7	79,0	22,4	5,3	2,3	2,5	0,0161	44
NMST 132S6	3	4	7,3 Δ	950	0,82	0,78	0,70	0,57	79,8	80,0	80,1	78,6	30,2	5,6	2,2	2,4	0,0299	65
NMST 132M6	4	5,5	9,3 Δ	955	0,83	0,80	0,71	0,59	80,4	81,4	80,8	80,0	40,0	5,6	2,2	2,5	0,0356	73
NMST 132M6	5,5	7,5	12,6 Δ	952	0,83	0,80	0,72	0,56	83,0	83,1	83,1	81,8	55,2	6,7	2,3	2,8	0,0420	80
NMST 160M6	7,5	10	16,4 Δ	964	0,85	0,82	0,73	0,60	82,5	84,7	84,2	80,1	74,3	6,7	2,6	2,8	0,0776	115
NMST 160Lb6	11	15	23,3 Δ	960	0,85	0,83	0,79	0,69	83,3	86,4	88,2	87,7	109,4	6,0	2,3	2,9	0,1085	140
NMST 180Lb6	15	20	30,8 Δ	967	0,85	0,84	0,81	0,72	87,1	88,0	88,0	86,7	148,1	6,5	2,4	2,7	0,1636	192
NMST 200L6	18,5	25	38,7 Δ	972	0,84	0,82	0,77	0,65	86,8	88,6	88,8	89,4	181,8	6,0	2,1	2,8	0,2291	242
NMST 200L6	22	30	45,1 Δ	970	0,84	0,83	0,79	0,70	87,7	89,2	89,3	88,5	216,6	6,2	2,2	3,3	0,2725	260
NMST 225M6	30	40	60,0 Δ	980	0,83	0,84	0,81	0,75	88,1	90,5	90,8	88,7	292,3	5,9	2,7	2,4	0,6592	350
NMST 225Md6	37	50	72,9 Δ	975	0,85	0,85	0,83	0,78	88,6	90,7	90,8	89,5	362,4	6,1	2,4	2,5	0,8042	400
NMST 250M6	37	50	74,6 Δ	980	0,85	0,83	0,81	0,72	89,8	90,8	90,8	89,3	360,6	5,5	2,2	2,3	0,9008	450
NMST 280S6	45	60	90,8 Δ	986	0,85	0,82	0,73	0,62	91,9	91,8	92,0	90,2	435,8	5,4	2,2	2,3	1,3770	600
NMST 280Ma6	55	75	112,1 Δ	990	0,83	0,81	0,76	0,65	92,1	92,0	92,2	90,2	530,6	6,5	3,0	2,4	1,6303	640
NMST 280Mc6	75	100	151,9 Δ	985	0,81	0,81	0,77	0,61	92,4	92,6	92,8	92,6	727,2	6,0	2,1	2,2	2,1922	700
NMST 315S6	75	100	146,0 Δ	985	0,84	0,84	0,80	0,72	92,1	92,9	93,2	92,0	727,2	6,0	1,8	2,3	2,2620	850
NMST 315Ma6	90	125	173,0 Δ	987	0,85	0,85	0,82	0,75	92,4	93,0	92,8	92,3	871,0	6,0	1,8	2,3	2,6707	900
NMST 315Ma6	110	150	208,5 Δ	988	0,86	0,85	0,81	0,70	94,3	94,3	95,4	95,5	1063,0	6,5	2,0	2,3	3,2155	940
NMST 315Ma6	132	180	248,9 Δ	987	0,87	0,86	0,82	0,73	92,7	93,7	93,9	92,6	1277,0	6,6	2,0	2,4	3,7604	1050
NMST 315L6	160	220	300,1 Δ	988	0,86	0,86	0,83	0,74	93,3	94,2	95,3	95,4	1547,0	6,2	1,9	2,3	4,5082	1120
NMST 355S6	160	220	300,4 Δ	988	0,84	0,86	0,85	0,79	90,8	94,1	93,7	92,6	1546,6	5,5	1,8	2,2	4,9211	1300
NMST 355S6	185	250	347,7 Δ	988	0,86	0,86	0,83	0,75	91,2	94,0	95,7	95,9	1788,2	5,5	1,8	2,2	5,3332	1380
NMST 355S6	200	270	378,7 Δ	990	0,85	0,85	0,82	0,75	93,8	94,4	94,8	95,9	1929,3	5,6	1,8	2,1	5,9923	1450
NMST 355S6	250	340	475,4 Δ	988	0,85	0,85	0,81	0,71	92,2	94,0	93,8	93,6	2416,5	5,5	1,8	2,1	7,3695	1700
NMST 355L6	315	430	595,8 Δ	989	0,86	0,85	0,81	0,70	93,9	94,5	95,7	94,1	3041,7	5,8	1,8	2,2	9,9995	1910

750 rpm		8 POLES										380 V		50 Hz				
TYPE	Rated Output		Rated Current	Rated Speed	Power Factor				Efficiency				Rated Torque	Starting Current	Starting Torque	Breakdown Torque	Moment of Inertia	Weight
Frame Size	kW	PS	I _N A	n rpm	Cos φ				η				M _N Nm	I _k /I _N	M _k /M _N	M _b /M _N	J _{MOT} kgm ²	kg
					%125	%100	%75	%50	%125	%100	%75	%50						
NMST 90L8	0,55	0,75	1,9 λ	673	0,78	0,71	0,61	0,48	58,2	61,0	61,4	58,5	7,8	3,0	1,6	1,8	0,0045	18
NMST 100L8	0,75	1	2,7 λ	689	0,75	0,68	0,58	0,46	57,9	61,0	62,5	58,2	10,4	3,0	1,6	1,8	0,0073	21
NMST 100L8	1,1	1,5	3,8 λ	691	0,73	0,70	0,63	0,43	61,4	63,0	64,3	60,8	15,2	3,2	1,7	2,0	0,0094	30
NMST 112M8	1,5	2	4,7 λ	706	0,72	0,68	0,61	0,49	71,9	72,0	73,1	70,2	20,3	4,2	2,1	2,2	0,0161	44
NMST 132S8	2,2	3	6,0 Δ	700	0,78	0,74	0,66	0,54	71,7	75,0	75,4	74,2	30,0	4,2	2,0	2,3	0,0352	65
NMST 132M8	3	4	8,1 Δ	707	0,73	0,70	0,63	0,52	79,5	80,0	80,2	79,0	40,5	4,4	2,1	2,3	0,0419	73
NMST 160M8	4	5,5	9,9 Δ	714	0,77	0,74	0,66	0,55	82,0	83,0	83,0	81,5	53,5	4,5	1,9	2,3	0,0782	80
NMST 160M8	5,5	7,5	14,3 Δ	715	0,76	0,73	0,65	0,55	80,0	80,0	80,3	78,8	73,5	5,3	2,1	2,6	0,0978	115
NMST 160Lb8	7,5	10	17,7 Δ	716	0,76	0,73	0,65	0,56	87,8	88,0	88,0	85,3	100,0	5,5	2,2	2,6	0,1316	140
NMST 180Lb8	11	15	26,2 Δ	715	0,80	0,77	0,71	0,61	82,0	83,0	83,2	83,0	147,0	5,5	2,0	2,7	0,2273	192
NMST 200L8	15	20	33,6 Δ	730	0,81	0,78	0,73	0,63	86,6	87,0	87,2	84,9	196,2	6,0	2,1	2,9	0,4118	242
NMST 225S8	18,5	25	39,9 Δ	728	0,84	0,80	0,82	0,65	85,9	88,0	88,3	86,2	242,7	6,0	1,9	2,7	0,5964	260
NMST 225M8	22	30	48,0 Δ	730	0,84	0,80	0,73	0,64	86,1	87,0	87,1	85,4	287,8	6,0	1,9	2,7	0,7147	350
NMST 250M8	30	40	63,3 Δ	737	0,84	0,80	0,74	0,65	89,2	90,0	89,9	87,2	388,7	6,0	1,9	2,6	0,9927	450
NMST 280S8	37	50	80,1 Δ	736	0,81	0,78	0,69	0,61	89,9	90,0	90,2	88,3	480,1	4,8	1,8	2,3	1,6303	600
NMST 280Ma8	45	60	96,2 Δ	732	0,83	0,79	0,71	0,63	89,3	90,0	90,3	88,3	587,0	4,8	1,8	2,2	1,7776	640
NMST 315S8	55	75	112,0 Δ	745	0,84	0,82	0,76	0,66	90,0	91,0	91,1	88,1	705,0	5,0	2,0	2,3	2,2620	600
NMST 315Ma8	75	100	149,4 Δ	740	0,85	0,82	0,78	0,67	91,5	93,0	93,2	89,6	967,9	5,7	1,8	2,2	3,0339	700
NMST 315Ma8	90	125	181,5 Δ	741	0,83	0,81	0,77	0,66	91,4	93,0	93,0	92,4	1159,9	5,7	1,8	2,2	3,5788	870
NMST 315Ma8	110	150	216,5 Δ	739	0,84	0,83	0,80	0,71	90,0	93,0	92,7	92,4	1421,5	5,8	1,7	2,1	4,3052	960
NMST 315L8	132	180	263,0 Δ	741	0,85	0,82	0,77	0,65	90,9	93,0	91,7	90,7	1701,2	6,2	1,8	2,0	5,1439	1070
NMST 355S8	132	180	260,2 Δ	740	0,81	0,82	0,80	0,71	91,4	94,0	95,3	97,9	1703,5	5,5	1,9	2,0	5,6506	1470
NMST 355S8	160	220	318,8 Δ	736	0,81	0,82	0,80	0,73	91,6	93,0	93,3	94,8	2076,1	5,5	1,9	2,0	6,6347	1690
NMST 355L8	185	250	364,7 Δ	740	0,85	0,82	0,80	0,73	93,9	94,0	94,7	96,0	2387,5	5,5	1,8	2,0	7,6510	1790
NMST 355L8	200	270	389,5 Δ	740	0,84	0,83	0,80	0,70	93,9	94,0	95,7	96,1	2581,1	5,4	1,8	2,0	8,2159	1850

Please visit our web site (www.elsanas.com.tr or www.emtas.com.tr) for the current dimensions and values.

DIMENSIONS - B3 FOOT MOUNTING

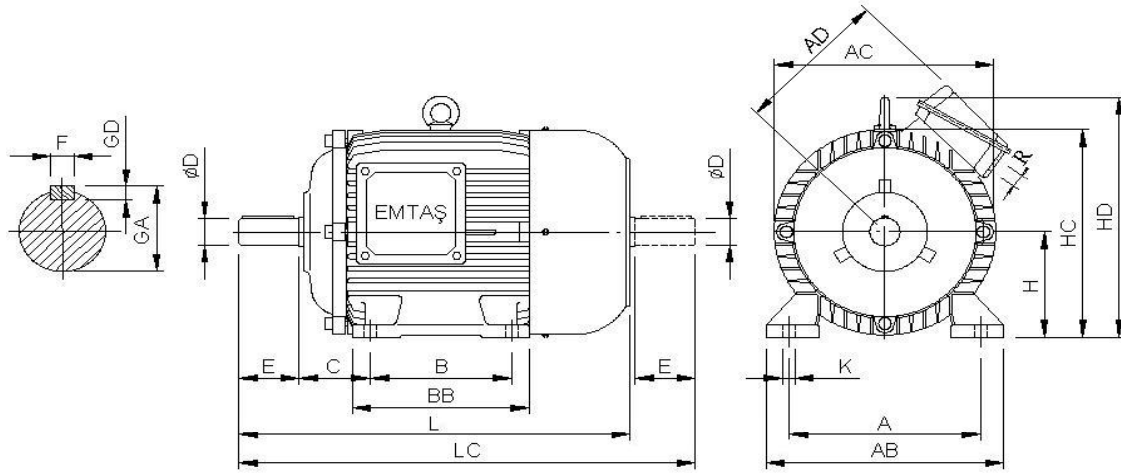

B3-V5-V6-B6-B7-B8

TYPE	POLES	H	A	B	C	AB	AC	AD	BB	HC	HD	K	L	LC	øD	E	F	GA	GD	R
NMST 90S	2,4,6,8	90	140	100	56	185	176	127	130	178	-	10	299	360	24	50	8	27	7	2 x Pg13,5
NMST 90L				125					150				324	385						
NMST 100L	2,4,6,8	100	160	140	63	200	194	138	175	197	-	12	386	453	28	60	8	31	7	2 x Pg13,5
NMST 112M	2,4,6,8	112	190	140	70	235	218	176	175	221	262	12	385	453	28	60	8	31	7	2 x Pg13,5
NMST 132S	2,4,6,8	132	216	140	89	270	258	207	180	261	309	12	454	540	38	80	10	41	8	2 x Pg21
NMST 132M				178					218				492	578						
NMST 160M	2,4,6,8	160	254	210	108	318	310	236	304	315	373	15	613	729	42	110	12	45	8	2 x Pg21
NMST 160Lb				254																
NMST 180M	2,4,6,8	180	279	241	121	360	348	250	327	354	411	15	651	772	48	110	14	51,5	9	2 x Pg21
NMST 180Lb				279																
NMST 200L	2,4,6,8	200	318	305	133	400	385	319	365	394	460	19	759	876	55	110	16	59	10	2 x Pg29
NMST 225S	4,8	225	356	286	149	436	434	300	346	442	504	19	793	940	60	140	18	64	11	2 x Pg36
NMST 225M	2	225	356	311	149	436	434	300	371	442	504	19	788	908	55	110	16	59	10	2 x Pg36
	4,6,8												818	965	60	140	18	64	11	
NMST 225Md	2	225	356	311	149	436	434	300	371	442	504	19	818	935	55	110	16	59	10	2 x Pg36
	4,6,8												848	995	60	140	18	64	11	
NMST 250M	2	250	406	349	168	485	480	345	410	490	552	24	907	1057	60	140	18	64	11	2 x Pg36
	4,6,8														65			69		
NMST 280S	2	280	457	368	190	536	536	381	439	548	613	24	993	1144	65	140	18	69	11	2 x Pg36
	4,6,8														75		20	79,5	12	
NMST 280Ma	2	280	457	419	190	536	536	381	490	548	613	24	993	1144	65	140	18	69	11	2 x Pg36
	4,6,8														75		20	79,5	12	
NMST 280Mc	2	280	457	419	190	536	536	381	490	548	613	24	1095	1246	65	140	18	69	11	2 x Pg36
	4,6,8														75		20	79,5	12	
NMST 315S	2	315	508	406	216	620	612	501	500	621	682	28	1090	1240	70	140	20	74,5	12	2 x ø50
	4,6,8												1120	1298	85	170	22	90	14	
NMST 315Ma	2	315	508	457	216	620	612	501	550	621	682	28	1090	1240	70	140	20	74,5	12	2 x ø50
	4,6,8												1120	1298	85	170	22	90	14	
NMST 315M	2	315	508	508	216	620	612	501	600	621	682	28	1141	1291	70	140	20	74,5	12	2 x ø50
NMST 315Lb	4,6,8												1171	1349	85	170	22	90	14	
NMST 315L	2	315	508	508	216	620	612	501	600	621	682	28	1241	1391	70	140	20	74,5	12	2 x ø50
	4,6,8												1311	-	100	210	28	106	16	
NMST 315Ld	2	315	508	508	216	620	612	501	600	621	682	28	1286	1436	70	140	20	74,5	12	2 x ø50
NMST 355S	4,6,8												1312	1532	100	210	28	106	16	
NMST 355L	4,8	355	610	500	254	718	700	552	670	705	838	33	1312	1532	100	210	28	106	16	2 x ø60
	6			630					800				1442	1662				110		

S, M, L : Lengths of feet
a, b, c, d : Lengths of frames

The dimensions are in "mm". Please visit our web site (www.elsanas.com.tr or www.emtas.com.tr) for the current dimensions and values.

DIMENSIONS - B5 (A) FLANGE MOUNTING

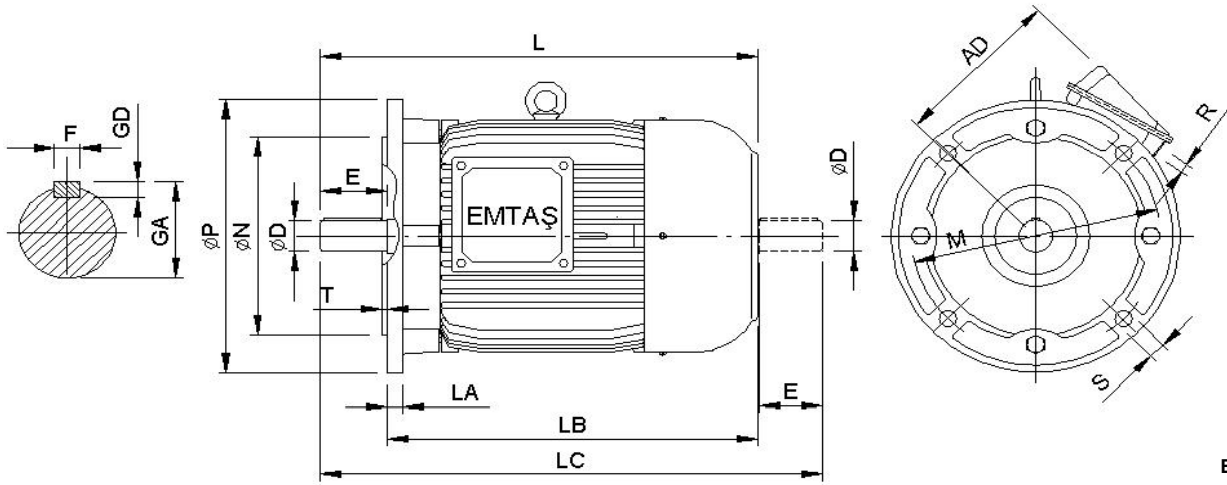

B5-V1-V3

TYPE		POLES	ØP	ØN	M	S	Nr. of Holes	T	AD	L	LA	LB	LC	ØD	E	F	GA	GD	R
NMST 90S	24 FF 165	2,4,6,8	200	130	165	12	4	3,5	127	299	11	249	360	24	50	8	27	7	2 x Pg13,5
										324		385							
NMST 100L	28 FF 215	2,4,6,8	250	180	215	15	4	4	138	386	14	326	453	28	60	8	31	7	2 x Pg13,5
NMST 112M	28 FF 215	2,4,6,8	250	180	215	15	4	4	176	385	14	325	453	28	60	8	31	7	2 x Pg13,5
NMST 132S	38 FF 265	2,4,6,8	300	230	265	15	4	4	207	454	18	374	540	38	80	10	41	8	2 x Pg21
										492		412	578						
NMST 160M	42 FF 300	2,4,6,8	350	250	300	19	4	5	236	613	18	503	729	42	110	12	45	8	2 x Pg21
NMST 180M	48 FF 300	2,4,6,8	350	250	300	19	4	5	250	651	18	541	772	48	110	14	51,5	9	2 x Pg21
NMST 200L	55 FF 350	2,4,6,8	400	300	350	19	4	5	319	759	18	649	876	55	110	16	59	10	2 x Pg29
NMST 225S	60 FF 400	4,8	450	350	400	19	8	5	300	793	18	653	940	60	140	18	64	11	2 x Pg36
NMST 225M	55 FF 400	2	450	350	400	19	8	5	300	788	18	678	908	55	110	16	59	10	2 x Pg36
	60 FF 400	4,6,8								818		678	965						
NMST 225Md	55 FF 400	2	450	350	400	19	8	5	300	818	18	708	935	55	110	16	59	10	2 x Pg36
	60 FF 400	4,6,8								848		708	995						
NMST 250M	60 FF 500	2	550	450	500	19	8	5	345	907	18	767	1057	60	140	18	64	11	2 x Pg36
	65 FF 500	4,6,8												65			69		
NMST 280S	65 FF 500	2	550	450	500	19	8	5	381	993	18	853	1144	65	140	18	69	11	2 x Pg36
	75 FF 500	4,6,8												75		79,5	12		
NMST 280Ma	65 FF 500	2	550	450	500	19	8	5	381	993	18	853	1144	65	140	18	69	11	2 x Pg36
	75 FF 500	4,6,8												75		79,5	12		
NMST 280Mc	65 FF 500	2	550	450	500	19	8	5	381	1095	18	955	1246	65	140	18	69	11	2 x Pg36
	75 FF 500	4,6												75		79,5	12		
NMST 315S	70 FF 600	2	660	550	600	24	8	6	501	1090	24	950	1240	70	140	20	74,5	12	2 x Ø50
	85 FF 600	4,6,8								1120		950	1298				85		
NMST 315Ma	70 FF 600	2	660	550	600	24	8	6	501	1090	24	950	1240	70	140	20	74,5	12	2 x Ø50
	85 FF 600	4,6,8								1120		950	1298				85		
NMST 315M	70 FF 600	2	660	550	600	24	8	6	501	1141	24	1001	1291	70	140	20	74,5	12	2 x Ø50
NMST 315Lb	85 FF 600	4,6,8	660	550	600	24	8	6	501	1171	24	1001	1349	85	170	22	90	14	2 x Ø50
NMST 315L	70 FF 600	2	660	550	600	24	8	6	501	1241	24	1101	1391	70	140	20	74,5	12	2 x Ø50
	100 FF 600	4,6,8								1311		1101	-				100		
NMST 315Ld	70 FF 600	2	660	550	600	24	8	6	501	1286	24	1146	1436	70	140	20	74,5	12	2 x Ø50
NMST 355S	100 FF 740	4,6,8	800	680	740	24	8	6	552	1312	25	1102	1532	100	210	28	106	16	2 x Ø60
NMST 355L	110 FF 740	4,8								1662		-	110				116		
			6							1442		1232	-	110					

S, M, L : Lengths of feet
a, b, c, d : Lengths of frames

The dimensions are in "mm". Please visit our web site (www.elsanas.com.tr or www.emtas.com.tr) for the current dimensions and values.

DIMENSIONS - B14 (C) FLANGE MOUNTING

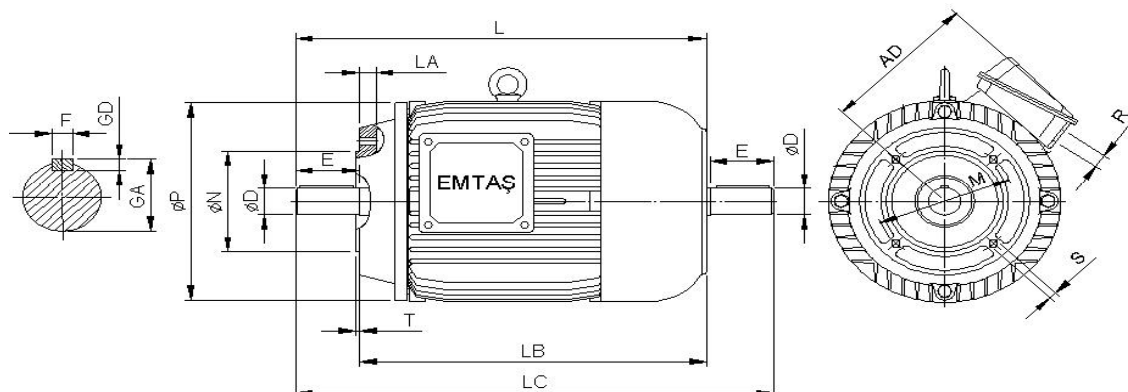

B14-V18-V19

TYPE	POLES	ØP	ØN	M	S	Nr. of Holes	T	AD	L	LA	LB	LC	ØD	E	F	GA	GD	R	
NMST 90S	24 FT 115	2,4,6,8	146	95	115	M8	4	3	127	299	15,5	249	360	24	50	8	27	7	2 x Pg13,5
NMST 90L										324		385							
NMST 100L	28 FT 130	2,4,6,8	162	110	130	M8	4	3,5	138	386	17	326	453	28	60	8	31	7	2 x Pg13,5
NMST 112M	28 FT 130	2,4,6,8	184	110	130	M8	4	3,5	176	385	16,5	325	453	28	60	8	31	7	2 x Pg13,5

The dimensions are in "mm". Please visit our web site (www.elsanas.com.tr or www.emtas.com.tr) for the current dimensions and values.

MOTOR COMPONENTS

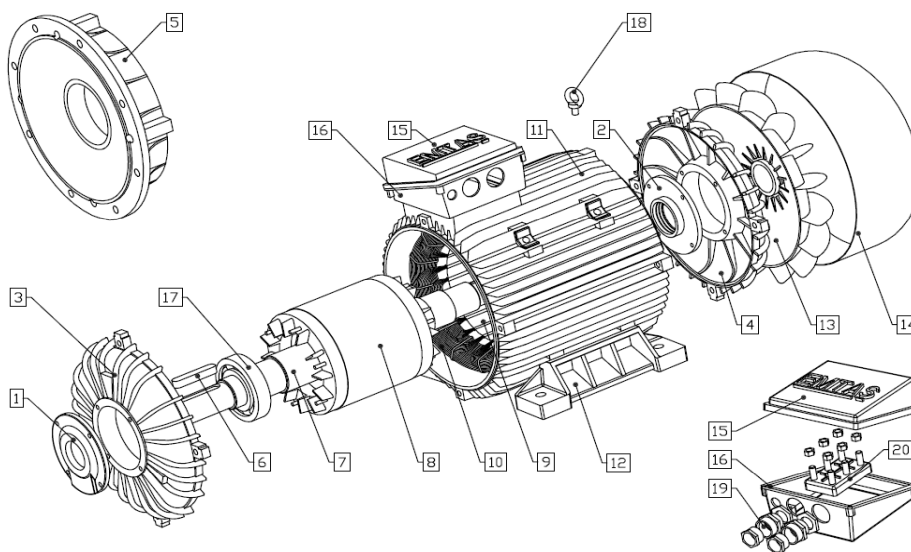

1	BEARING CAP - OUTER *	11	FRAME
2	BEARING CAP - INNER *	12	FEET
3	END SHIELD - DE	13	FAN
4	END SHIELD - NDE	14	FAN COWL
5	B5-FLANGE	15	TERMINAL BOX COVER
6	KEY	16	TERMINAL BOX
7	SHAFT	17	BEARING
8	ROTOR	18	LIFTING EYE
9	STATOR	19	CABLE GLAND
10	WINDING	20	TERMINAL TABLE

* These parts are used on 225 size and bigger.

OTHER PRODUCTS



TWO SPEED MOTOR



VIBRATION MOTOR



SLIP RING MOTOR

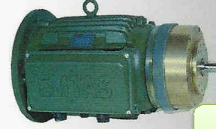

BRAKE MOTOR



SUBMERSIBLE MOTOR



VERTICAL HOLLOW SHAFT
(VHS) MOTOR



ELEVATOR MOTOR

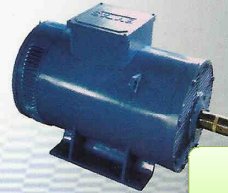

OPEN DRIP PROOF MOTOR



ELSAN ELEKTRİK SAN. ve TİC. A.Ş.

BÜRO & FABRİKA

Etiler Mah. Fabrika Cad. 1458. Sokak No:
40
Etimesgut - 06790 - ANKARA
Tel: 0.312.244 09 94
Faks: 0.312.243 14 38

İSTANBUL TEMSİLCİLİK

Okçumusa Cad. Midilli Sok. No: 2/203
Karaköy - 80050 - İSTANBUL
Tel: 0.212.252 36 96
Faks: 0.212.243 06 80

İZMİR TEMSİLCİLİK

GOP Bulvarı No: 30 Süreyya Reyant İşhanı
No: 8/803
Çankaya - İZMİR
Tel: 0.232.441 94 93
Faks: 0.232.441 97 96